

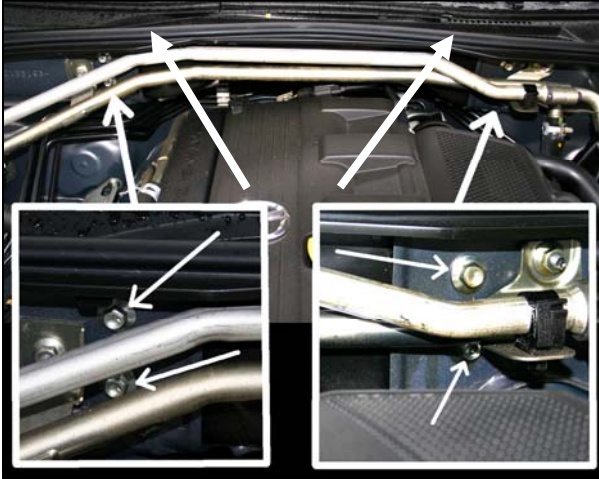

Preparation installation front upper strut brace for models **without** OEM strut brace (Pic 1/1a)



pic 1



pic 1a

To mount the front upper strut brace you will need to exchange the center strut mounting bracket. You can start by uninstalling the wiper arms and the cowl grill, below the front windshield. All mounting screws you need should be visible now (pic1). The old bracket is removed and exchanged for the new bracket (pic 1a) you can re-use the old screws, please torque to 7,8 – 11 Nm.

Remove the OEM strut bar mounting brackets (left and right) on top of the shock towers ( pic 2 pos 1) Before removing the mounting brackets please remove the i-Loop and /or PCM unit / brackets from the strut bar mounting brackets when your vehicle is equipped with these options. Now you can install the I.L.Motorsport aluminium shock tower brace / front upper strut brace (pic 3) .

### Installation aluminium upper strut brace for vehicles with OEM Strut Brace

Uninstall the OEM shock tower brace / upper strut brace. (pic 2)

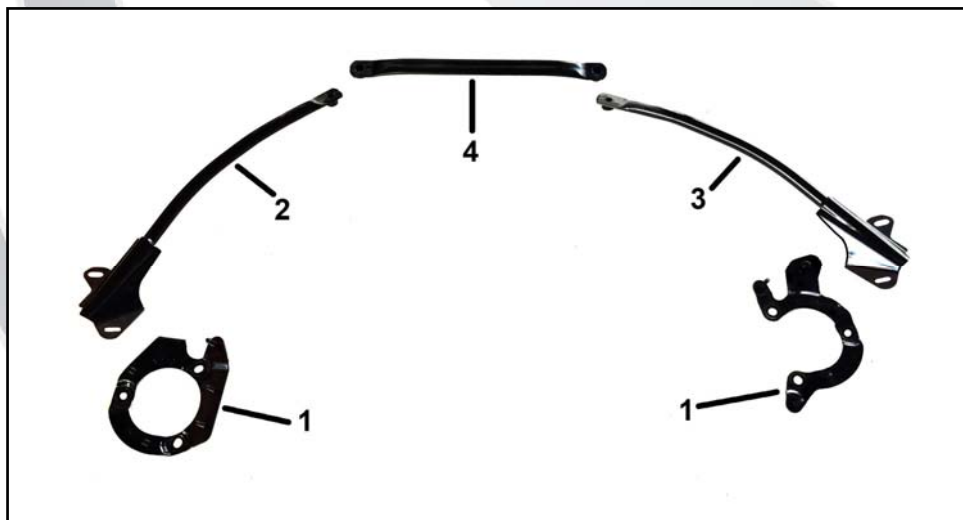

pic 2

Please remove the short centre brace first (nr. 4), now remove both left and rightside braces (nr 2 & 3) . To remove both left- and rightside strut mounting brackets (nr 1) loosen all mounting nuts and when applicable the nuts of the i-Loop and PCM sensor brackets.



### Installation aluminium upper strut brace (pic 3)

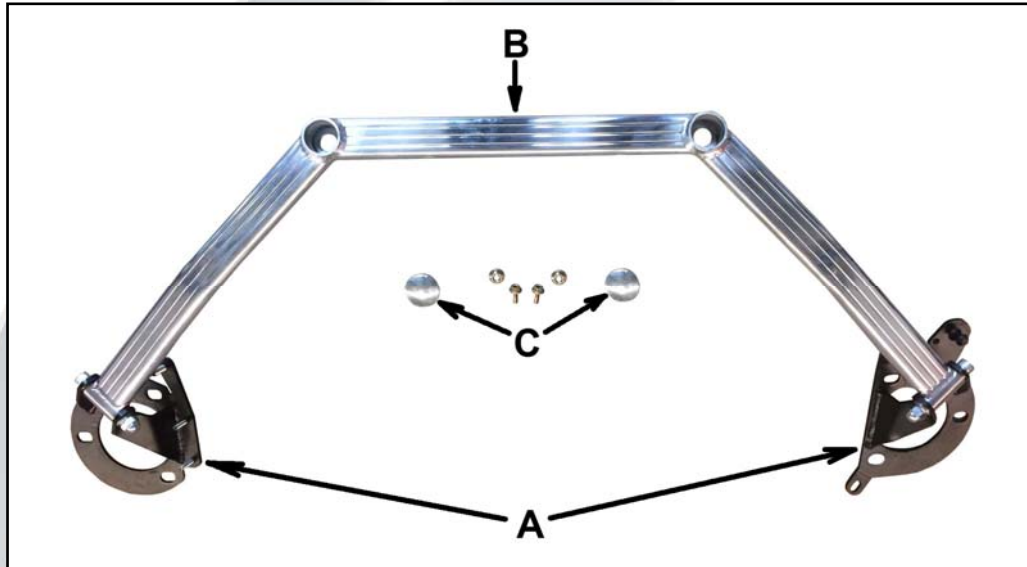

pic 3

Position the strut mounting brackets (A) on the shock towers and fixate loosely with the OEM nuts.

Now install the i-Eloop and PCM-Sensor brackets on their respective positions on the strut mounting brackets.

Please use the supplied screws to fixate the PCM sensor.

Now position the aluminium strut brace (B) on the mounting position near the firewall and fixate the strut bar to the mounting brackets on the shock towers.

Now torque the the strut mounting brackets (A) to 46 - 60 Nm.

Now torque the two connection points near the firewall with the supplied nuts to 16 - 27 Nm.

Finally torque the screws connected to the strut mounting bracket (A) and the PCM and i-Eloop to 16 - 27 Nm

You can now insert the aluminium cover (C) into the upper left and right corner of the strut brace.

**Tip:** put a little lubricant on the rubber ring of the strut bar cover.